

Project: Quilted Hanging Organizer

INSPIRED BY DRESSED TO IMPRESS FROM DESIGNER MONICA SOLORIO-SNOW OF HAPPY ZOMBIE (THEHAPPYZOMBIE.COM)
PROJECT TESTER: MARY PEPPER



Use fat quarter pieces and printed panels to create a handy hanging organizer for your sewing room. A fussy-cut panel section from the Mrs. Sew & Sew collection by Dan Morris for RJR Fabrics (rjrfabrics.com) is centered on the front of each storage pocket.

Project: Quilted Hanging Organizer

Materials

- 12—18×22" pieces (fat quarters) assorted novelty prints (pocket linings, sashing squares)
- 2—sewing machine print panels with 6 sewing machine motifs per panel or 1 yard desired print (pockets)
- ¾ yard black tone-on-tone (sashing)
- ½ yard tan stripe (binding)
- 1¾ yards backing fabric
- 63×72" rectangle batting

Finished quilt: 32½×50½"

Finished pocket: 8×10"

Quantities are for 44/45"-wide, 100% cotton fabrics.

Measurements include ¼" seam allowances. Sew with right sides together unless otherwise stated.

Cut Fabrics

Cut pieces in the following order.

From each assorted novelty print, cut:

- 1—10×10½" rectangle
- 1—8½×10½" rectangle
- 2—2½" sashing squares (you will use 20 of the 24 total cut)

From each sewing machine print panel, fussy-cut:

- 6—10×10½" rectangles, centering sewing machine motif (Side edges should be 10"; see **Diagram 1**)

From black tone-on-tone, cut:

- 16—2½×10½" sashing rectangles
- 15—2½×8½" sashing rectangles

From tan stripe, cut:

- 5—2½×42" binding strips

From batting, cut:

- 1—41×59" rectangle
- 12—9¾×10½" rectangles

Assemble Pockets

1. Sew together a novelty print 10×10½" rectangle and a sewing machine print 10×10½" rectangle along long top edge (**Diagram 1**). Press seam toward novelty print.

2. Fold Step 1 unit wrong sides together along seam. Referring to **Diagram 2**, place a batting 9¾×10½" rectangle between layers and press. Pin layers together.

3. Using thread that matches background of sewing machine print, machine-straight-stitch around edges of sewing machine motif to make a quilted rectangle (**Diagram 3**).

4. Referring to **Diagram 4**, use a pencil to mark dots on bottom edge of quilted rectangle 1" and 2" from left-hand edge. Repeat marking from right-hand edge.

5. Fold and match dot pairs to make pleats; pin pleats in place (**Diagram 5**).

6. Aligning bottom and side edges, pin Step 5 piece atop matching novelty print 8½×10½" rectangle. Using ⅛" seam allowances, machine-baste around side and bottom edges to make a pocket (**Diagram 6**).

7. Repeat steps 1-6 to make 12 pockets total.

Assemble Quilt Top

1. Referring to **Quilt Assembly Diagram**, lay out pockets, black tone-on-tone sashing rectangles, and novelty print sashing squares in nine rows.

2. Join pieces in each row; be careful not to get pockets caught in seams. Press seams away from sashing rectangles.

3. Join rows to complete quilt top. Press seams toward block rows.

Finish Quilt

1. Layer quilt top, batting, and backing; baste. Quilt as desired.

2. Bind with tan stripe binding strips.

Project: Quilted Hanging Organizer

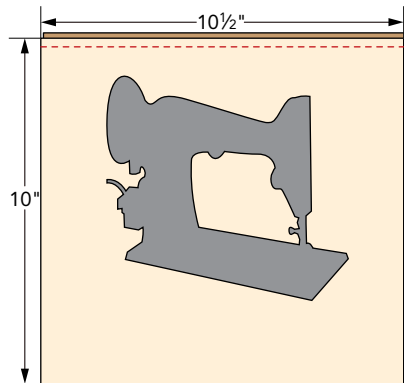

DIAGRAM 1

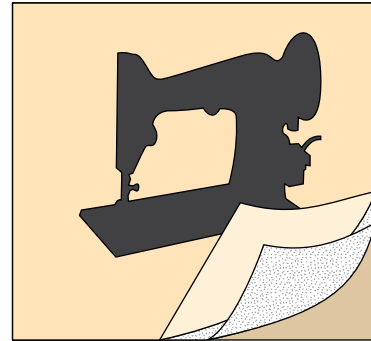

DIAGRAM 2

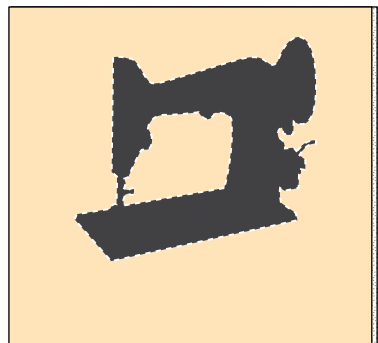

DIAGRAM 3

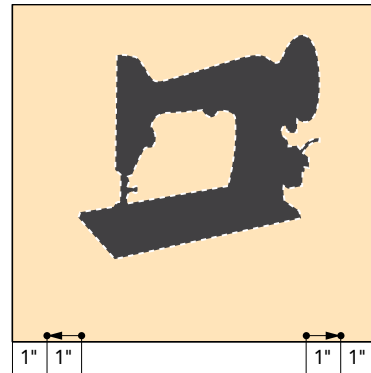

DIAGRAM 4

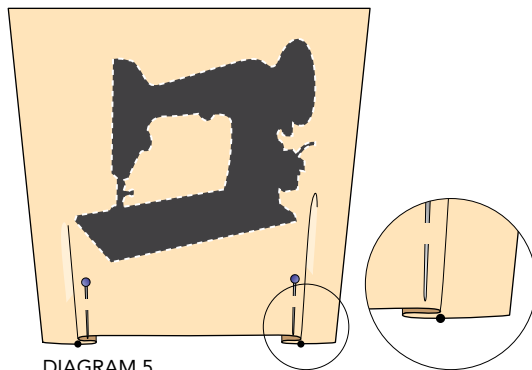

DIAGRAM 5

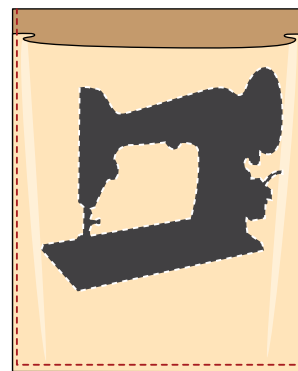
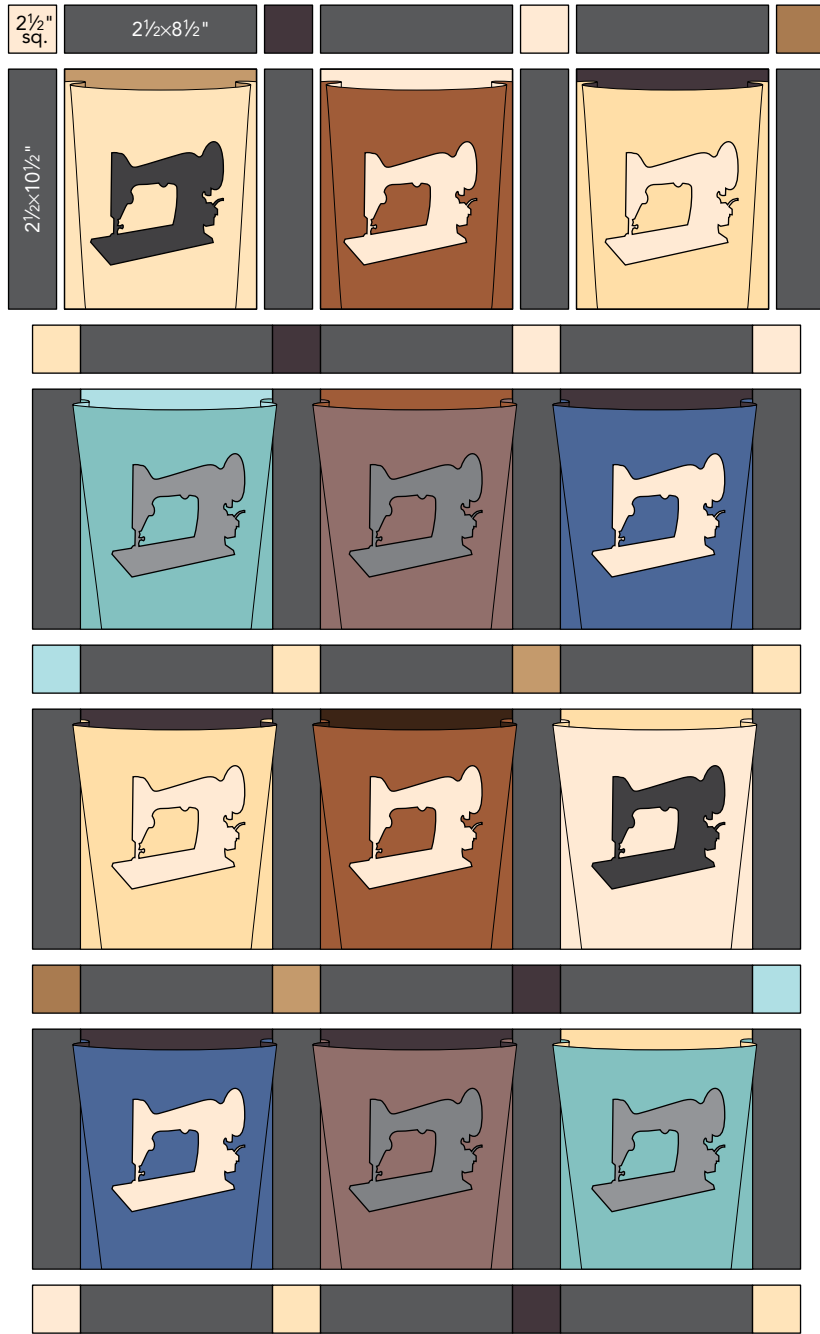

DIAGRAM 6

Project: Quilted Hanging Organizer



QUILT ASSEMBLY DIAGRAM