

Project: Mini Log Cabin Bag

SCRAP LAB

Do you like to make the most of everything? Experiment with our challenge to create something special from a specific set of materials.

DESIGNER: BARBARA J. EIKMEIER OF (BARBSFAVORITES.COM)



You can create this scrappy Log Cabin tote from 5" squares in a weekend's time!

FABRICS are from the Vintage Shirting & Dress Prints 1880-1910 collection by Barbara J. Eikmeier for Paintbrush Studio (fabri-quilt.com).

Project: Mini Log Cabin Bag

Materials

- 2—5" squares red print (blocks)
- 18—5" squares total assorted cream prints and light blue prints (blocks)
- 18—5" squares total assorted dark blue prints and black prints (blocks, handles)
- 2—5" squares blue print (handles)
- $\frac{3}{8}$ yard lining print
- $\frac{3}{8}$ yard thin batting

Finished bag: $8\frac{1}{2} \times 9\frac{1}{2} \times 1\frac{1}{2}$ "

Finished block: $3\frac{1}{2}$ "

Yardages and cutting instructions are based on 42" of usable fabric width and precut 5" squares.

Measurements include $\frac{1}{4}$ " seam allowances. Sew with right sides together unless otherwise stated.

Cut Fabrics

Cut pieces in the following order.

From red print, cut:

- 18—1" squares

From each cream print and light blue print, cut:

- 1— $1 \times 3\frac{1}{2}$ " rectangle
- 1— 1×3 " rectangle
- 1— $1 \times 2\frac{1}{2}$ " rectangle
- 1— 1×2 " rectangle
- 1— $1 \times 1\frac{1}{2}$ " rectangle
- 1—1" square

From each dark blue print and black print, cut:

- 1— 1×4 " rectangle
- 1— $1 \times 3\frac{1}{2}$ " rectangle
- 1— 1×3 " rectangle
- 1— $1 \times 2\frac{1}{2}$ " rectangle
- 1— 1×2 " rectangle
- 1— $1 \times 1\frac{1}{2}$ " rectangle

From lining print, cut:

- 1— $11 \times 21\frac{1}{2}$ " rectangle

From thin batting, cut:

- 1— $11 \times 21\frac{1}{2}$ " rectangle

Assemble Log Cabin Blocks

1. Join a red print 1" square and a cream or light blue print 1" square (Diagram 1).
2. Add a matching cream or light blue print $1 \times 1\frac{1}{2}$ " rectangle to top edge of Step 1 unit (Diagram 2).
3. Add a dark blue or black print $1 \times 1\frac{1}{2}$ " rectangle to left edge of Step 2 unit (Diagram 3).
4. Add a matching dark blue or black print 1×2 " rectangle to bottom edge of Step 3 unit (Diagram 4).
5. Referring to Diagram 5, continue adding rectangles in counterclockwise sequence to make a block. Press each seam toward just-added rectangle. The block should be 4" including seam allowances.
6. Repeat steps 1–5 to make 18 blocks total.

Assemble Handles

1. Join blue print 5" squares to form a $5 \times 9\frac{1}{2}$ " rectangle (Diagram 6). Cut rectangle in half lengthwise to form two $2\frac{1}{2} \times 9\frac{1}{2}$ " strips for handles.
2. With right side inside, sew together long raw edges of a Step 1 strip (Diagram 7). Turn strip right side out and press, centering seam on underside.
3. Sew four rows of stitching $\frac{1}{4}$ " apart on Step 2 strip to make a handle.
4. Repeat steps 1–3 to make a second handle.

Assemble Bag Body

1. Referring to Diagram 8, lay out blocks in six horizontal rows, paying attention to the position of the dark halves of the Log Cabin blocks.
2. Sew together blocks to make bag body; press seams in one direction. The bag body should be $11 \times 21\frac{1}{2}$ " including seam allowances.
3. Referring to Diagram 9, position ends of one handle along one short edge of bag body, $3\frac{1}{2}$ " from each long edge. Baste in place. Repeat with remaining handle on remaining short edge.
4. With right sides together, position bag body $11 \times 21\frac{1}{2}$ " lining rectangle on top of $11 \times 21\frac{1}{2}$ " batting rectangle. Referring to Diagram 10, sew layers together, leaving a 5" opening for turning.
5. Turn bag body right side out through opening. Slip-stitch opening closed.
6. Quilt the bag body as desired. Designer Barbara J. Eikmeier stitched between each Log Cabin block, then topstitched around the bag body.

Finish Bag

1. Fold bag body in half with right sides and handles together to form a $10\frac{1}{2} \times 10\frac{1}{2}$ " square (Diagram 11). Sew side edges together to make bag.
2. To shape bag bottom, at one corner match side seam and bottom center of bag to create a flattened triangle (Diagram 12). Measuring 1" from point of

Project: Mini Log Cabin Bag

triangle, draw a 1½"-long line across triangle. Sew on drawn line. Repeat with remaining corner. Turn right side out to make finish bag.

Project: Mini Log Cabin Bag

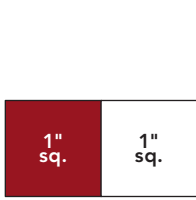

DIAGRAM 1

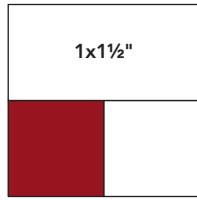

DIAGRAM 2



DIAGRAM 3

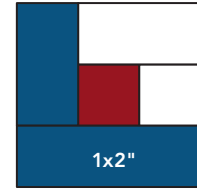

DIAGRAM 4

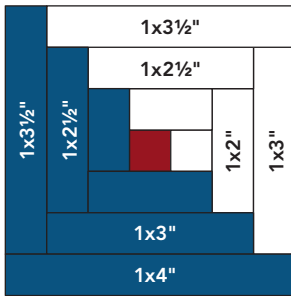

DIAGRAM 5

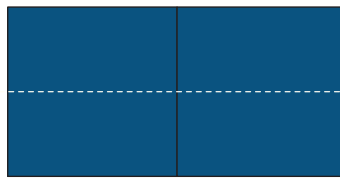

DIAGRAM 6

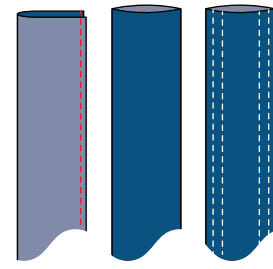

DIAGRAM 7

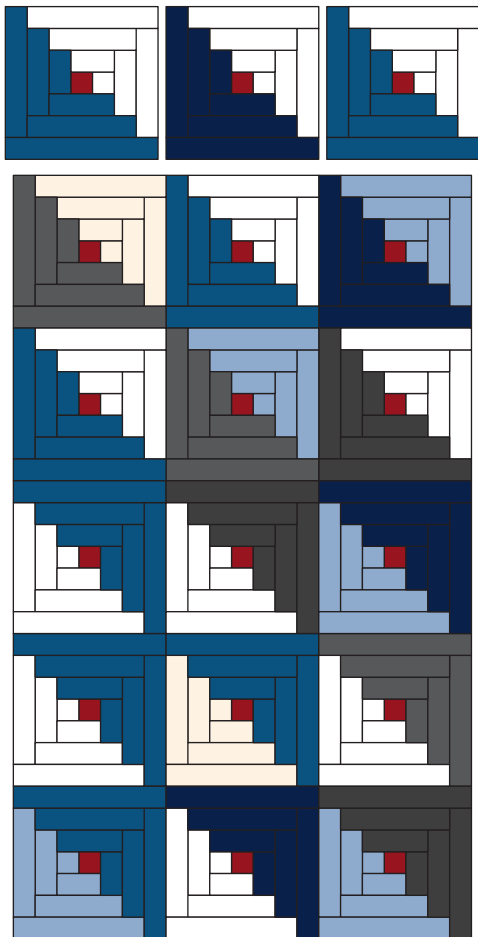

DIAGRAM 8

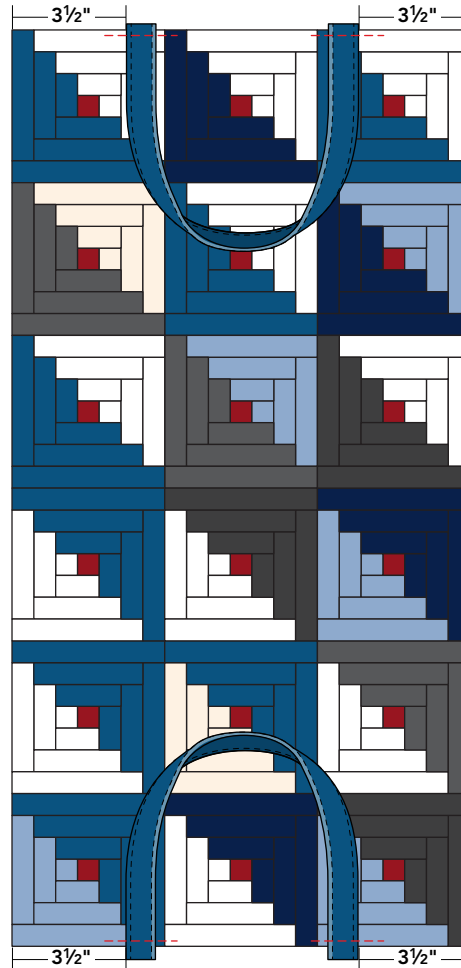

DIAGRAM 9

Project: Mini Log Cabin Bag

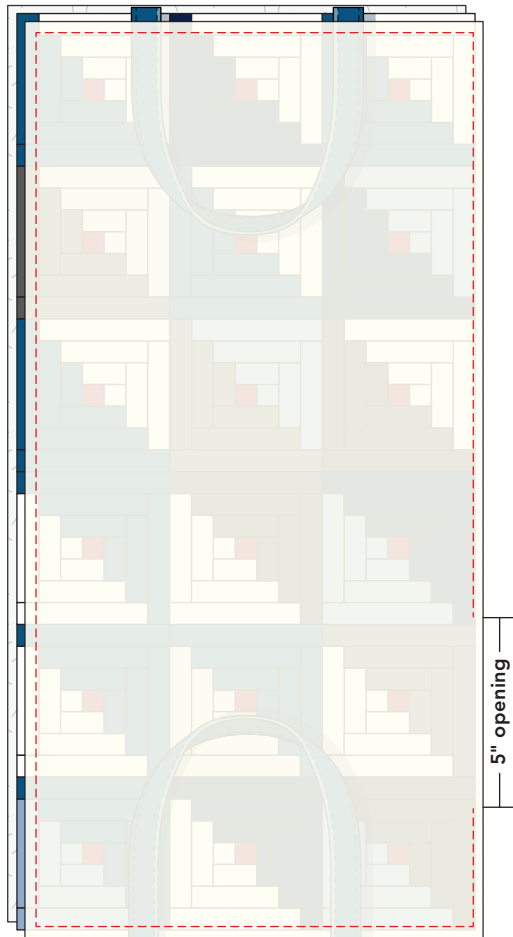

DIAGRAM 10

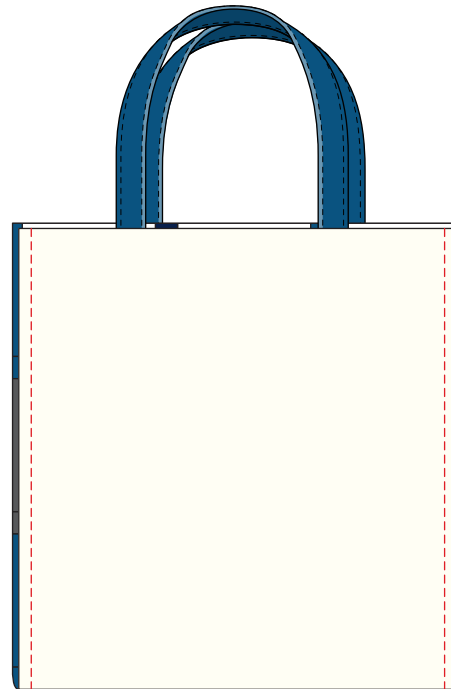

DIAGRAM 11

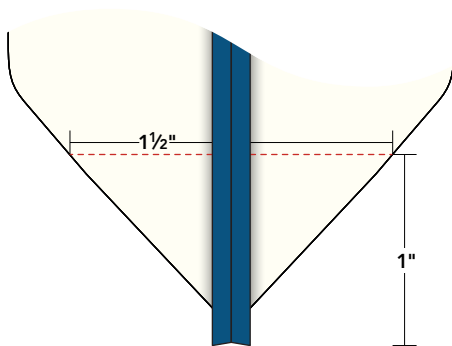

DIAGRAM 12