

Project: Shades of Lavender

INSPIRED BY HOMEMADE HAPPINESS FROM DESIGNER JOANNA FIGUEROA OF FIG TREE & CO. (FIGTREEQUILTS.COM)



FABRICS are from the Piccadilly collection by Paintbrush Studio (fabri-quilt.com).

Geometric patterns in springtime colors take center stage on this delightful pillow duet.

Project: Shades of Lavender

Materials for Small Pillow

- ¼ yard total assorted prints in purple, aqua, and teal (pillow top)
- ⅓ yard large floral (pillow top)
- ⅓ yard backing fabric
- 12"-square pillow form

Finished small pillow: 12" square

Yardages and cutting instructions are based on 42" of usable fabric width.

Measurements include ¼" seam allowances. Sew with right sides together unless otherwise stated.

Cut Fabrics

Cut pieces in the following order.

From assorted prints, cut:

- 12—2½" squares

From large floral, cut:

- 2—2½×12½" rectangles
- 2—2½×8½" rectangles
- 1—4½" square

From backing fabric, cut:

- 2—8¾×12½" rectangles

Assemble Small Pillow Top

1. Referring to **Diagram 1**, sew together two assorted print 2½" squares to make a short inner border. Press seam in one direction. The short inner border should be 2½×4½" including seam allowances. Repeat to make a second short inner border.
2. Sew together four assorted print 2½" squares to make a long inner border. Press seams in one direction. The long inner border should be 2½×8½" including seam allowances. Repeat to make a second long inner border.

3. Join short inner borders to opposite edges of large floral print 4½" square. Add long inner borders to remaining edges to make center unit (**Diagram 2**). Press all seams toward large floral print square. The center unit should be 8½" square including seam allowances.
4. Join large floral 2½×8½" rectangles to opposite edges of center unit. Add large floral 2½×12½" rectangles to remaining edges to make small pillow top (**Diagram 3**). Press all seams toward center unit.

Finish Small Pillow

1. Turn under ¼" along one long edge of each backing fabric 8¾×12½" rectangle; press. Turn under same long edges ¼" again; press. Topstitch folded edges to hem pillow back pieces.
2. Referring to **Diagram 4**, overlap hemmed edges of pillow back pieces about 4" to make a 12½" square. Stitch across overlaps to make pillow back.
3. Layer small pillow top and pillow back with right sides together. Stitch around all edges to make pillow cover. Turn right side out through opening in pillow back; press. Insert 12"-square pillow form to complete pillow.

Materials for Large Pillow

- ⅝ yard total assorted prints in teal, aqua, and purple (pillow top)
- ⅜ yard backing fabric
- 18"-square pillow form

Finished large pillow: 18" square

Yardages and cutting instructions are based on 42" of usable fabric width.

Measurements include ¼" seam allowances. Sew with right sides together unless otherwise stated.

Cut Fabrics

Cut pieces in the following order.

From assorted prints, cut:

- 2—4½×18½" rectangles
- 5—2½×18½" rectangles

From backing fabric, cut:

- 2—11¾×18½" rectangles

Assemble Large Pillow Top

1. Referring to **Diagram 5**, lay out assorted print 4½×18½" and 2½×18½" rectangles.
2. Join rectangles to make large pillow top. Press seams in one direction.

Finish Large Pillow

1. Turn under ¼" along one long edge of each backing fabric 11¾×18½" rectangle; press. Turn under same long edges ¼" again; press. Topstitch folded edges to hem pillow back pieces.
2. Referring to **Diagram 6**, overlap hemmed edges of pillow back pieces about 4" to make an 18½" square. Stitch across overlaps to make pillow back.
3. Layer large pillow top and pillow back with right sides together. Stitch around all edges to make pillow cover. Turn right side out through opening in pillow back; press. Insert 18"-square pillow form to complete pillow.

Project: Shades of Lavender



DIAGRAM 1

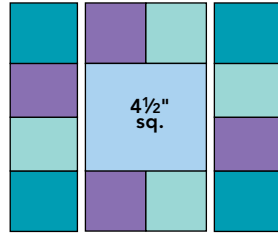

DIAGRAM 2

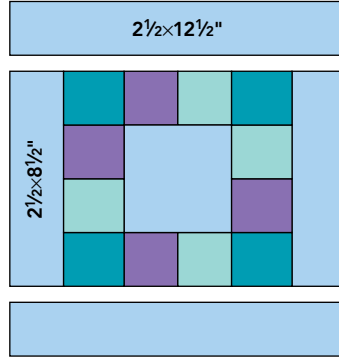

DIAGRAM 3

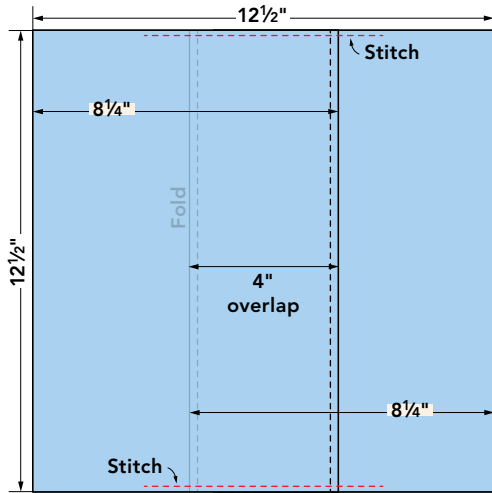

DIAGRAM 4

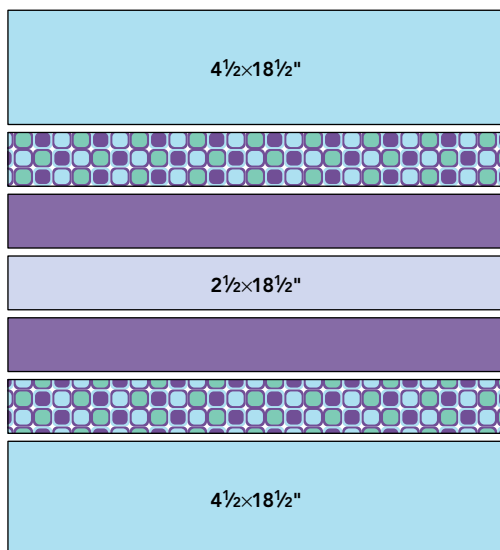

DIAGRAM 5

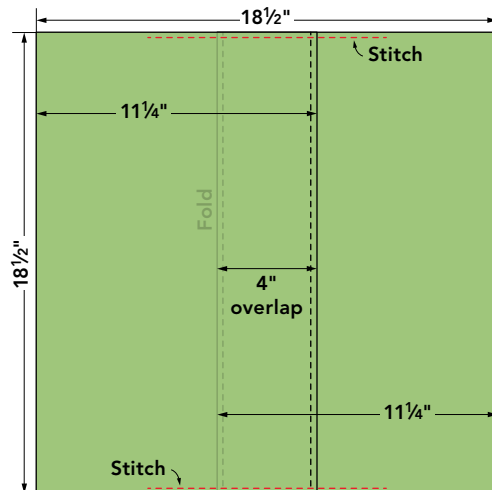

DIAGRAM 6