

Project: Icy Blues

INSPIRED BY TREE TOPS FROM DESIGNER JOCELYN UENG OF IT'S SEW EMMA (ITSSEWEMMA.COM)
QUILT TESTER: JAN RAGALLER



FABRICS are from the Indigo Patchwork collection by Connecting Threads (connectingthreads.com).

Combine shades of blue, white, and gray to create a wintertime wall hanging that lasts well past the holiday season.

Project: Icy Blues

Materials

- 2—18×21" pieces (fat quarter) assorted white prints (blocks)
- 3—18×21" pieces (fat quarter) assorted light blue prints (blocks)
- ¾ yard navy blue stripe (blocks, border, binding)
- ⅝ yard gray print (blocks)
- 2—18×21" pieces (fat quarter) assorted blue prints (blocks)
- 3—9×21" pieces (fat eighth) assorted dark blue prints (blocks)
- 1½ yards backing fabric
- 30×52" batting

Finished quilt: 21½×43½"

Finished blocks: 12×20", 6×20"

Yardages and cutting instructions are based on 42" of usable fabric width.

Measurements include ¼" seam allowances. Sew with right sides together unless otherwise stated.

Cut Fabrics

Cut pieces in the following order.

From each white print, cut:

- 6—6½" squares
- 2—2½×5½" rectangles

From each light blue print, cut:

- 2—6½×12½" rectangles

From navy blue stripe, cut:

- 4—2½×42" binding strips
- 5—2×42" strips for border
- 2—2½" squares
- 4—1½" squares

From gray print, cut:

- 24—3½" squares
- 8—1½×3" rectangles

From each blue print, cut:

- 3—3½×6½" rectangles

From each dark blue print, cut:

- 2—3½×6½" rectangles

Assemble Large Tree Blocks

1. Use a pencil to draw a diagonal line on wrong side of each white print 6½" square. (To prevent fabric from stretching as you draw the lines, place 220-grit sandpaper under each square.)
2. Align a marked white print square with one end of an assorted light blue print 6½×12½" rectangle (**Diagram 1**; note direction of drawn line). Sew on marked line; trim seam allowances to ¼". Press open attached triangle.
3. Align a matching marked white print square with opposite end of Step 2 rectangle (**Diagram 1**; again note direction of marked line). Stitch, trim, and press as before to make a large Flying Geese unit (**Diagram 2**). The unit should be 12½×6½" including seam allowances.
4. Repeat steps 2 and 3 to make six large Flying Geese units total.
5. Referring to **Diagram 3**, sew together two matching white print 2½×5½" rectangles and one navy blue stripe 2½" square to make a large trunk unit. Press seams toward dark blue stripe square. The large trunk unit should be 12½×2½" including seam allowances. Repeat to make a second large trunk unit.
6. Referring to **Diagram 4**, sew together three large Flying Geese units and a large trunk unit with matching backgrounds to make a large tree block. Press seams toward top of block. The block should be 12½×20½"

including seam allowances. Repeat with remaining Flying Geese units and large trunk unit to make a second large tree block.

Assemble Small Tree Blocks

1. Use a pencil to draw a diagonal line on wrong side of each gray print 3½" square.
2. Referring to **Assemble Large Tree Blocks**, steps 2 and 3, use 12 marked gray print squares and blue print 3½×6½" rectangles to make six small blue Flying Geese units. Each unit should be 6½×3½" including seam allowances.
3. Repeat Step 2 using remaining marked gray print squares and the dark blue print 3½×6½" rectangles to make six small dark blue Flying Geese units.
4. Referring to **Assemble Large Tree Blocks**, Step 5, use gray print 1½×3" rectangles and navy blue stripe 1½" squares to make four small trunk units. Each unit should be 6½×1½" including seam allowances.
5. Referring to **Diagram 5**, sew together three small blue Flying Geese units, three small dark blue Flying Geese units, and two small trunk units to make a small tree block. Press seams toward top of block. The block should be 6½×20½" including seam allowances. Repeat to make a second small tree block.

Project: Icy Blues

Assemble Quilt Center

1. Referring to **Quilt Assembly Diagram**, lay out large tree blocks and small tree blocks in pairs.
2. Sew together block pairs. Press seams toward large tree blocks. Join pairs to make quilt center. Press seams toward top of quilt center. The quilt center should be $18\frac{1}{2} \times 40\frac{1}{2}$ " including seam allowances.
4. With right sides together, match marked seam lines and pin together (**Diagram 8**). Beginning with a backstitch at inside corner, sew strips together, stitching exactly on marked lines. Check right side to see that corner lies flat. Trim excess fabric, leaving a $\frac{1}{4}$ " seam allowance. Press seam open (**Diagram 9**).
5. Repeat steps 3 and 4 with remaining border corners to complete quilt top.

Add Border

To make mitered corners in the border as shown in the featured wall hanging, complete the following steps.

1. Cut and piece navy blue stripe 2×42 " strips to make:
 - 2— 2×54 " border strips
 - 2— 2×32 " border strips
2. Aligning midpoints, sew short border strips to short edges of quilt center, beginning and ending seams $\frac{1}{4}$ " from corners (**Diagram 6**). In the same manner, sew long border strips to remaining edges.
3. Referring to **Diagram 7**, lap one border strip over the other. Using the edge of an acrylic ruler, mark a diagonal line from border seam corner to intersection of strip raw edges. Then place bottom border strip on top and repeat marking process.

Finish Quilt

1. Layer quilt top, batting, and backing; baste. Quilt as desired.
2. Bind with navy blue stripe binding strips.

Project: Icy Blues

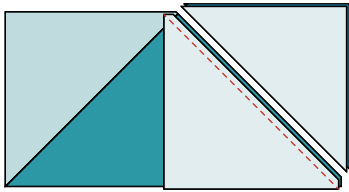
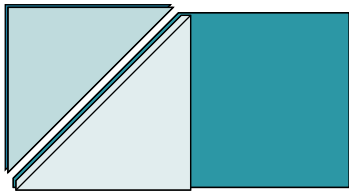

DIAGRAM 1

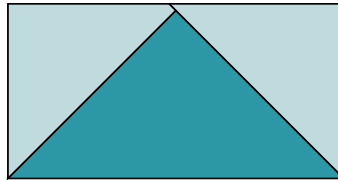

DIAGRAM 2

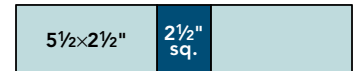

DIAGRAM 3

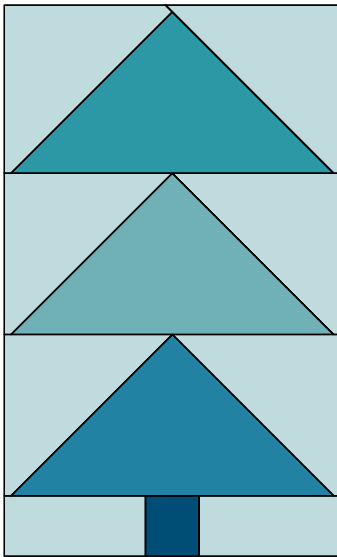

DIAGRAM 4

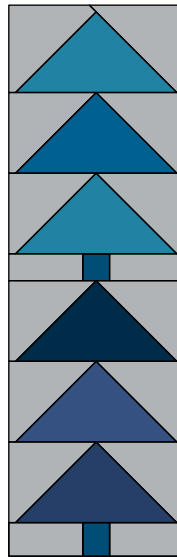

DIAGRAM 5

Project: Icy Blues

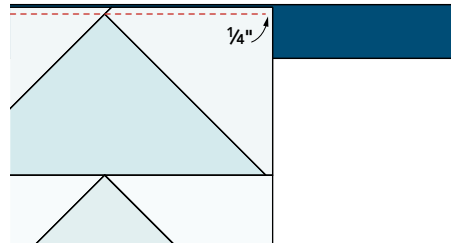

DIAGRAM 6

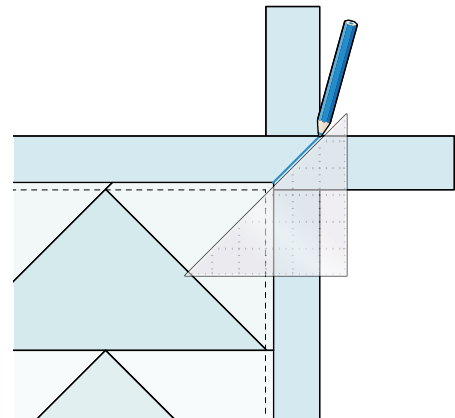

DIAGRAM 7

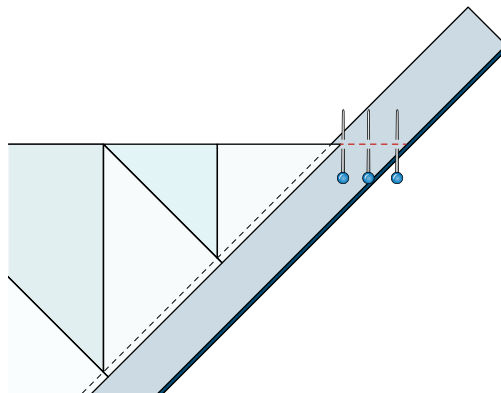

DIAGRAM 8

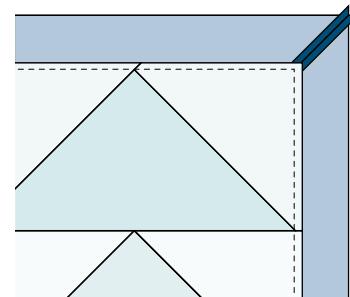
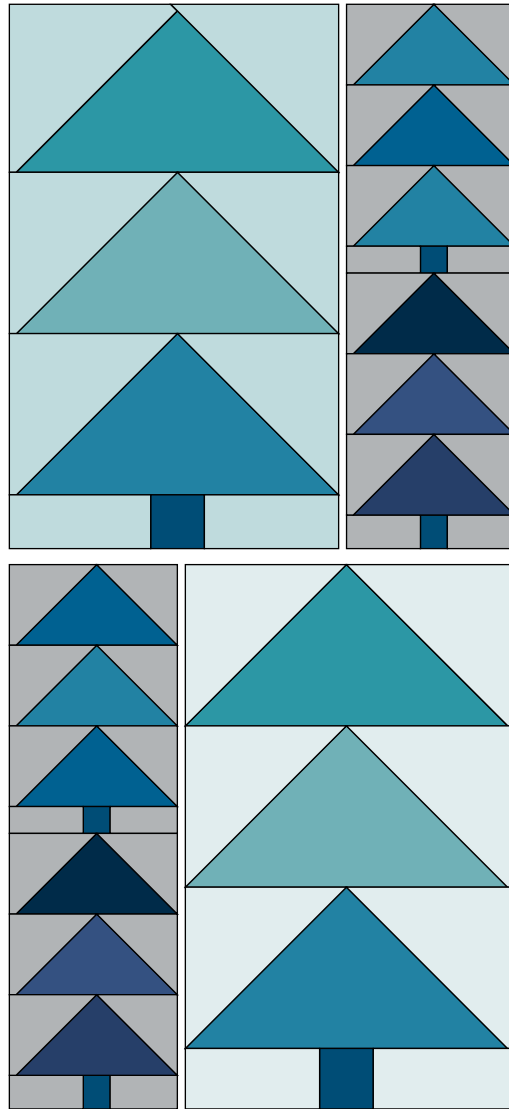

DIAGRAM 9

Project: Icy Blues



QUILT ASSEMBLY DIAGRAM