

# WOODStore.net

Browse more than 1000 plans, projects, books, techniques, & more

## Thank You!

Thank you for ordering a WOOD® magazine download. We hope you enjoy being part of our online experience and that you have fun expanding your woodworking skills.

Please remember that this copyrighted material is for your use only. It is unlawful to share this file with someone else or to reprint it in any form.

Bill Krier  
Editor in Chief, WOOD magazine

## Adobe Acrobat Reader Troubleshooting Guide

If you can read this page, your Acrobat Reader program is working correctly! But you may still have problems or specific issues, such as printing and saving your downloadable file.

My printer won't print the text correctly  
Almost all printing problems are due to not enough free system resources memory. The files are very memory intensive because they include graphics, text, and photos. Close all other programs/applications and print directly out of the Acrobat Reader program, not your Web browser.

Patterns are not printing full-size  
Make sure your printer is set to print at 100 percent and that "print to fit" is not checked. These settings are selected in the printer setup or printer options.

I can't save my file now that it's downloaded  
You must save the plan when you download the file. Download the file again, except this time try right-clicking on the red download button. A menu window will open. Select "Save target as" or "Save link as" to save the file to your hard drive. Once saved, you can open it up with Adobe Acrobat Reader.

For more details on using Adobe Acrobat Reader please visit our online help section at:  
<http://www.woodstore.net/clicherforde.html>

## WOOD Store Customer Favorites

### Shop Tools & Accessories



### Indoor Furniture



### Outdoor Furniture

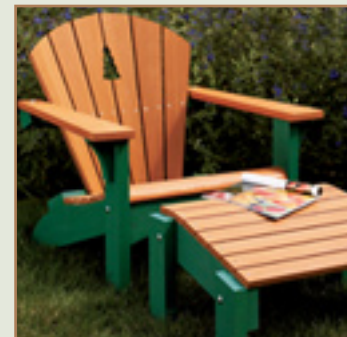

### Mission Furniture



Visit the WOOD Store at:  
**WOODStore.net**

# SHOPMADE TABLESAW MITER SLED

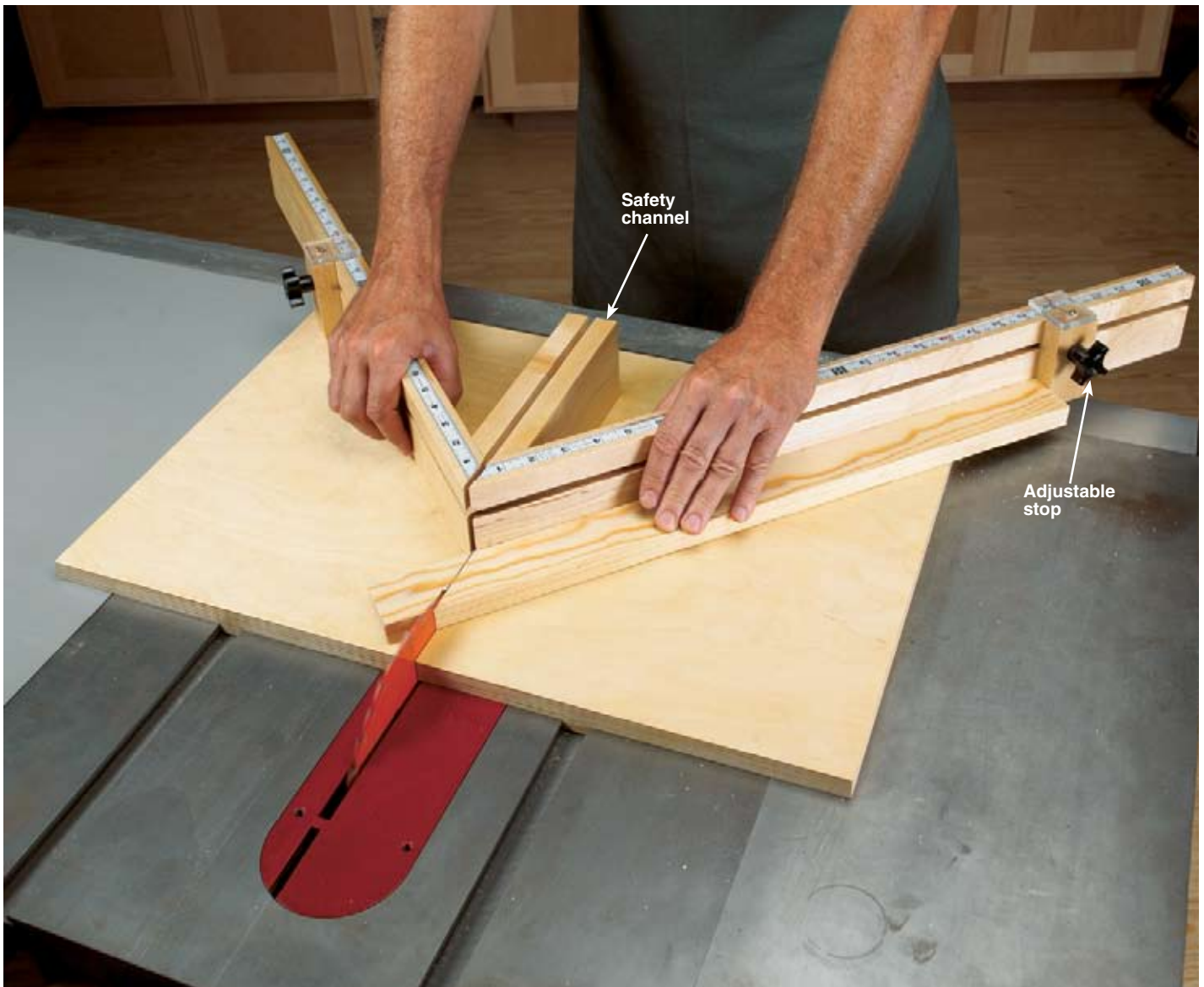

## FENCE END VIEW

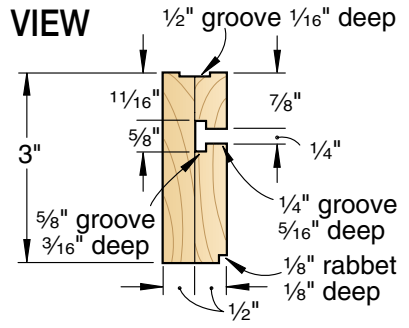

## MITER SLED

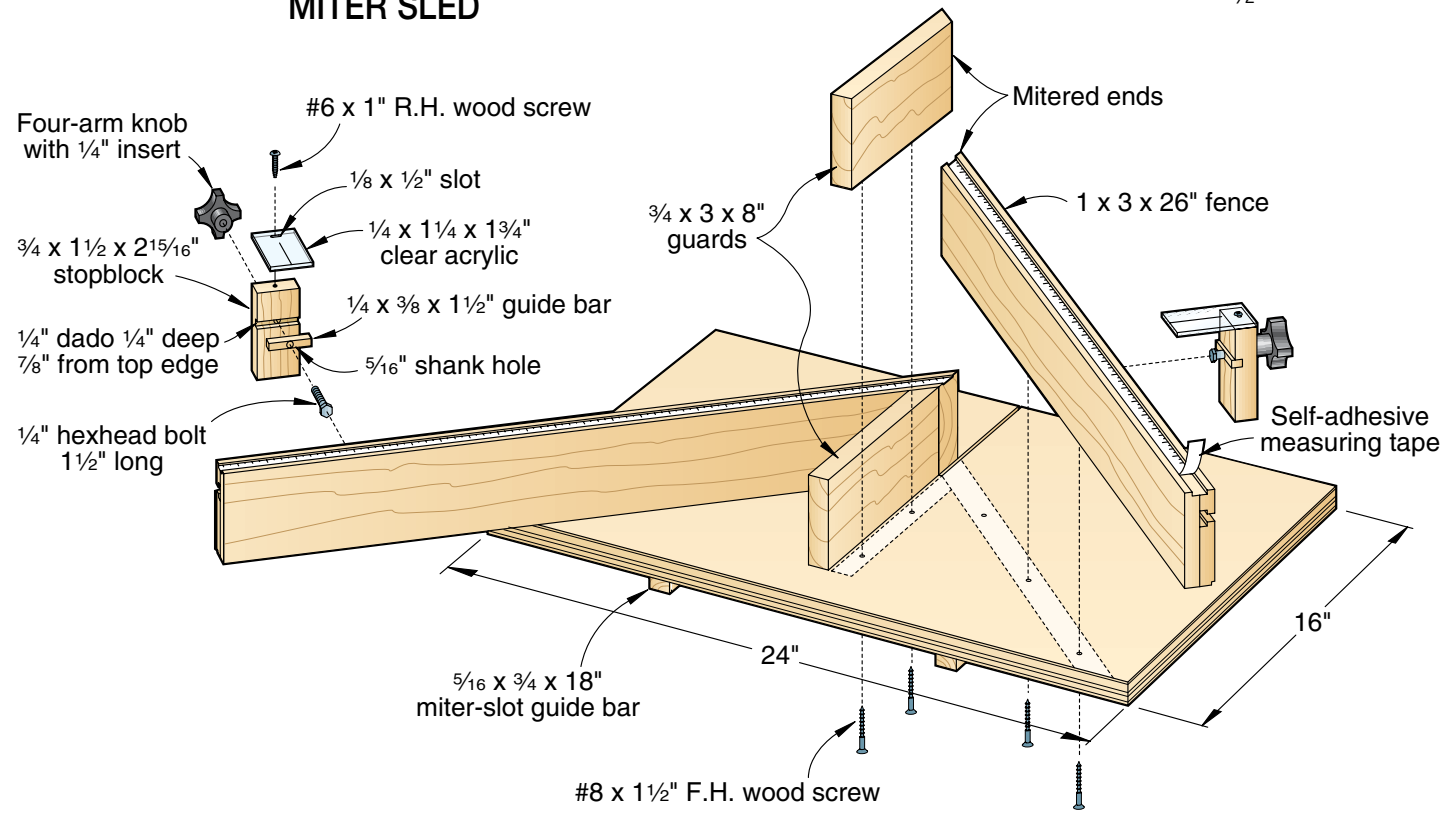

**T**his miter-cutting sled offers a dual-rail guidance system that rides in the miter-gauge slots of your tablesaw and smooth-acting stops that ride in tracks. It also features a safety channel down the middle to keep your hands away from the table-saw blade.

To build the jig, see the drawing above for the dimensions. We used Baltic birch for the base and hard maple for the other parts. Refer to the photos on next page for building tips that guarantee an exact fit on your saw and a pair of perfectly aligned miter fences. Use

an 80-tooth crosscut blade for smooth, ready-to-glue surfaces.

To make two workpieces of equal length, start by measuring and marking your first workpiece. Miter one end of the workpiece as marked, using the appropriate fence, and then transfer the workpiece to the opposite fence. Line up the mark with the blade, slide the stop against the already mitered end, tighten it, and make the second cut. Leave the stop in place, and miter the second workpiece in the same sequence. Remember to stop your cut when the blade's highest point passes

through the fence to avoid weakening the sled base. 🌳

### PROS:

- ◆ Fast cuts, even in thick, hard materials.
- ◆ Combination of tablesaw and jig provides accurate, consistent, and smooth cuts.
- ◆ Makes fine trimming cuts.
- ◆ Inexpensive to build.

### CONS:

- ◆ Hard to handle long workpieces.
- ◆ Dedicated to 45° cuts only.



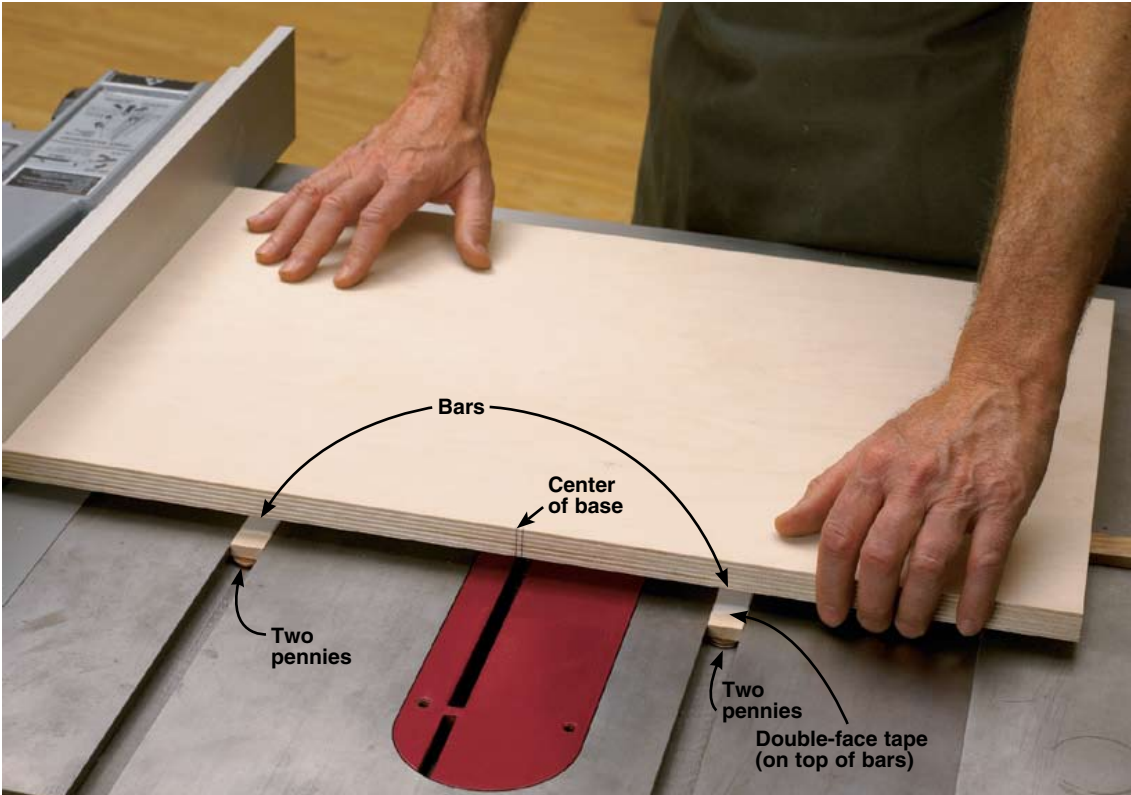

To fit the guide bars to your miter sled, place two stacks of two pennies in each miter-gauge slot on your table saw to serve as shims. Place a bar in each slot, and apply double-face tape to the top of each bar. Mark the center of the sled base, and locate the rip fence to place that mark over the blade. Press the base against the bars, remove the assembly from the saw, and permanently attach the bars with screws. Remove the pennies from the slots.

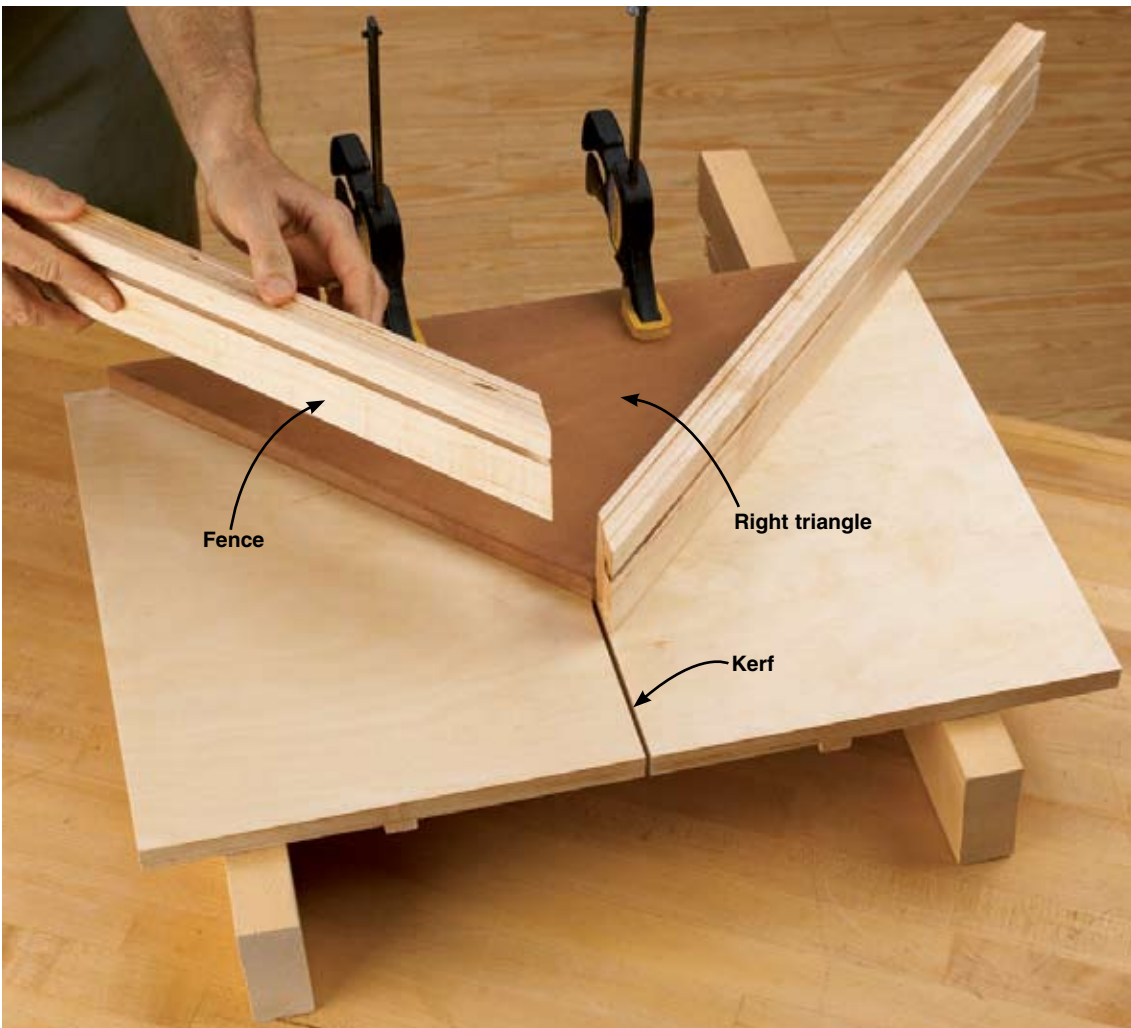

Place the sled on your table saw, and cut a kerf about 6" long to serve as a visual guide for placing the fences. Now, cut a right triangle measuring 21½" on its long edge to fit on the miter sled base as shown. Place it flush with the back edge of the sled, centered from side to side, and clamp it in position to serve as a guide for installing the miter fences. Apply double-faced tape to the bottom of each fence, and press them into place. Remove the clamps and triangle guide, and make test cuts in scrap to check your sled's accuracy. When it's dead-on, permanently attach the fences with screws, making sure that they sit perpendicular to the sled base.

# More from WOOD Magazine

## WOODStore.net

Browse more than 1,000 woodworking project plans, articles, tool reviews, books, techniques, & more. Each plan includes step-by-step instructions, professional color photography, and detailed illustrations.



Plans

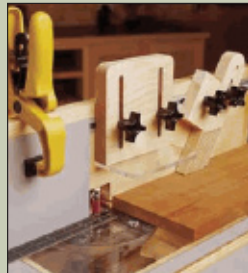

Techniques



Articles



Publications

## WOODmagazine.com

### A WEALTH OF INFORMATION JUST A CLICK AWAY

The online presence of WOOD magazine, WOODmagazine.com speaks to online users of all woodworking skill levels with free woodworking plans, helpful forums, numerous articles, to help you become a better woodworker.



## WOODWorkersCenter.com

### LOOKING FOR INFORMATION FROM LEADING WOODWORKING COMPANIES?

WOODWorkersCenter.com is just the site for your woodworking tool, accessory, and service informational needs. Use the online info request feature to request these companies latest catalogs or info.



## WOODmagazine.com/videos



**PROFESSIONAL, PORTABLE VIDEO**  
The biggest names in woodworking help you build your skills with downloadable videos.



**FREE MAGAZINE SUPPORT 24/7**  
WOOD magazine editors provide more than 120 streaming videos, from 2 to 10 minutes in length.



**BY WOODWORKERS, FOR WOODWORKERS**  
Watch free videos of other woodworkers showing their stuff.



**WATCH A DEMO BEFORE YOU BUY**  
Don't spend a penny on a tool or accessory until you learn how it works and what it can do.