

Mini lathe

EXPLODED VIEW

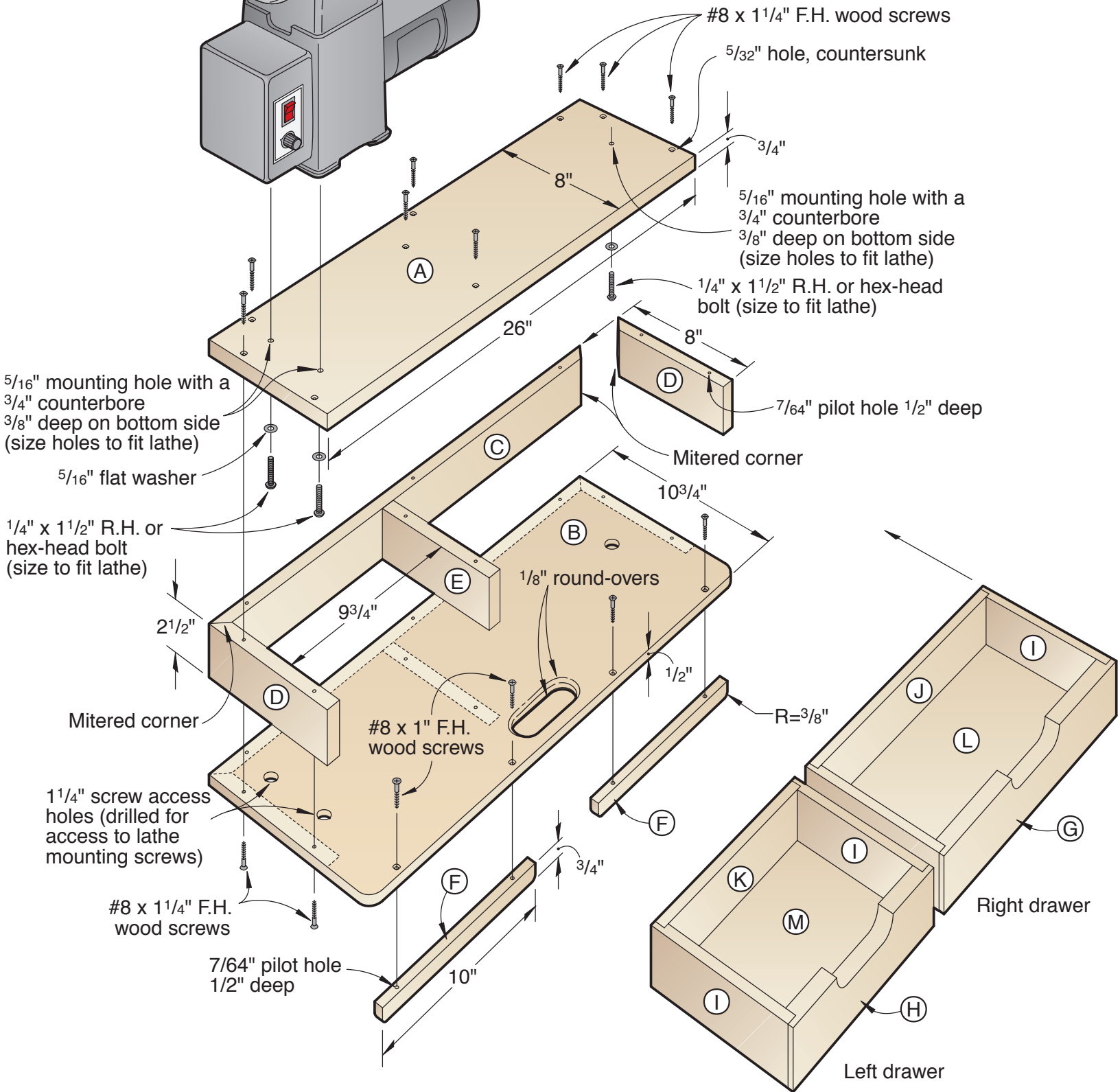

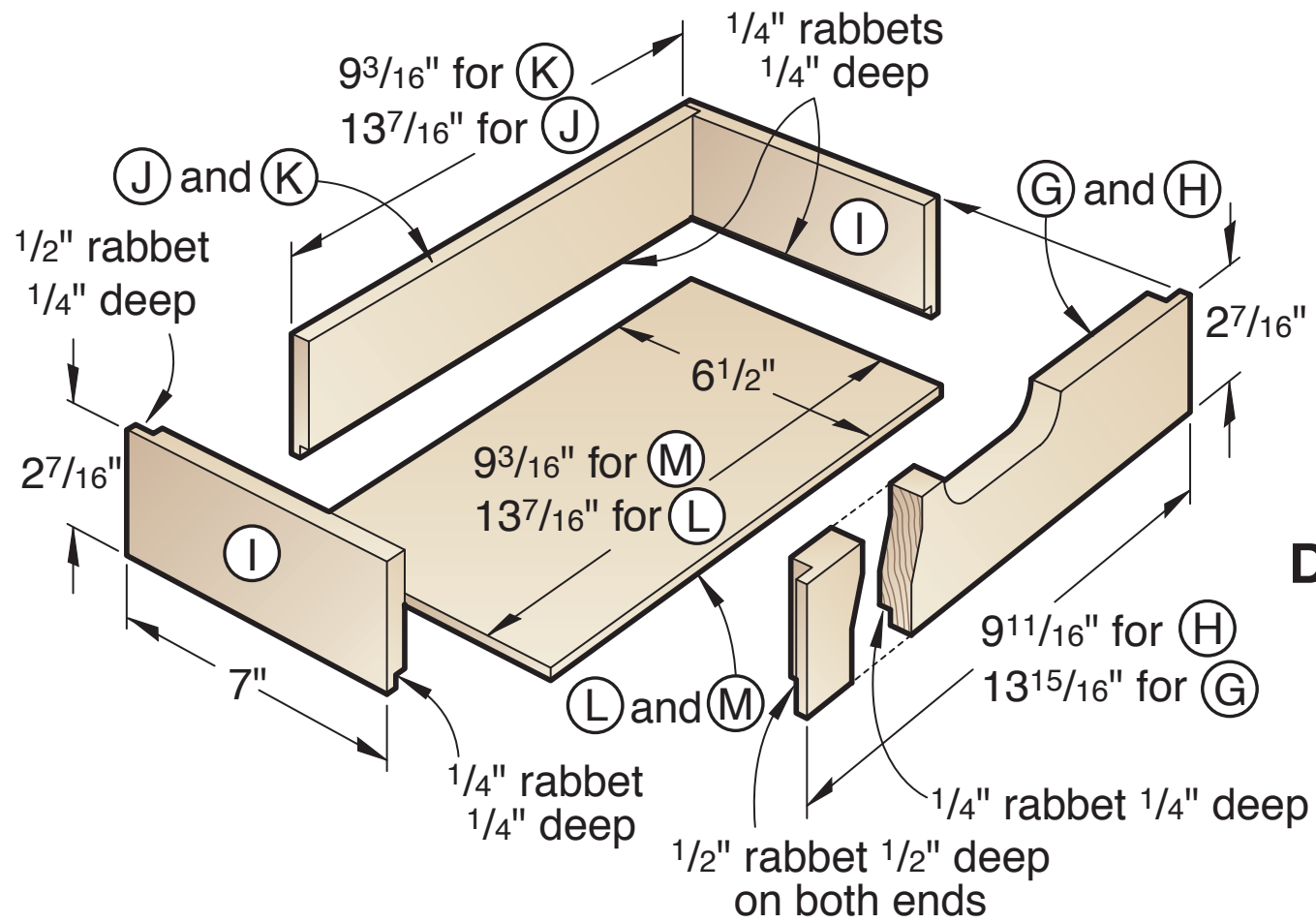

DRAWERS

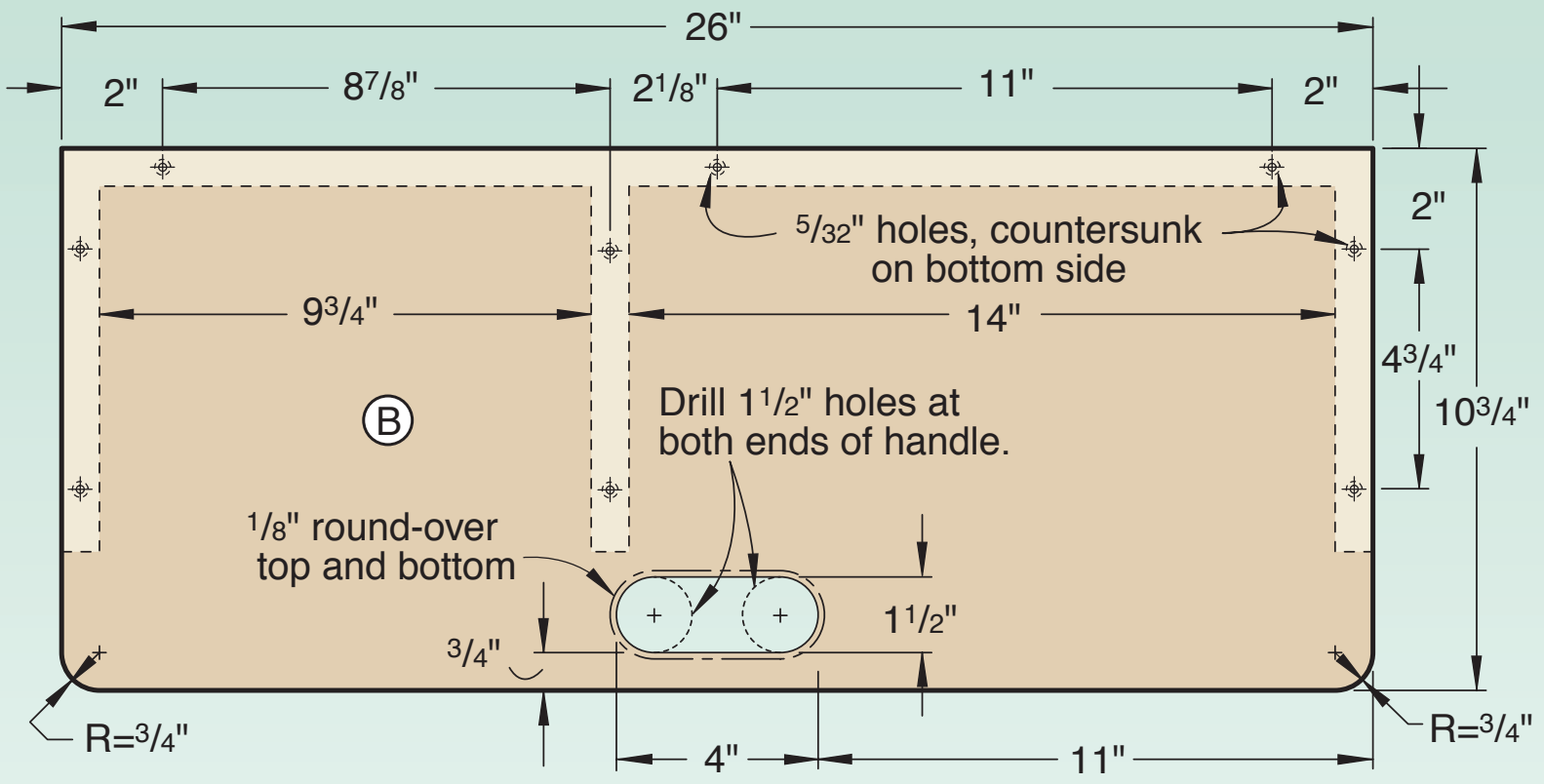

BOTTOM

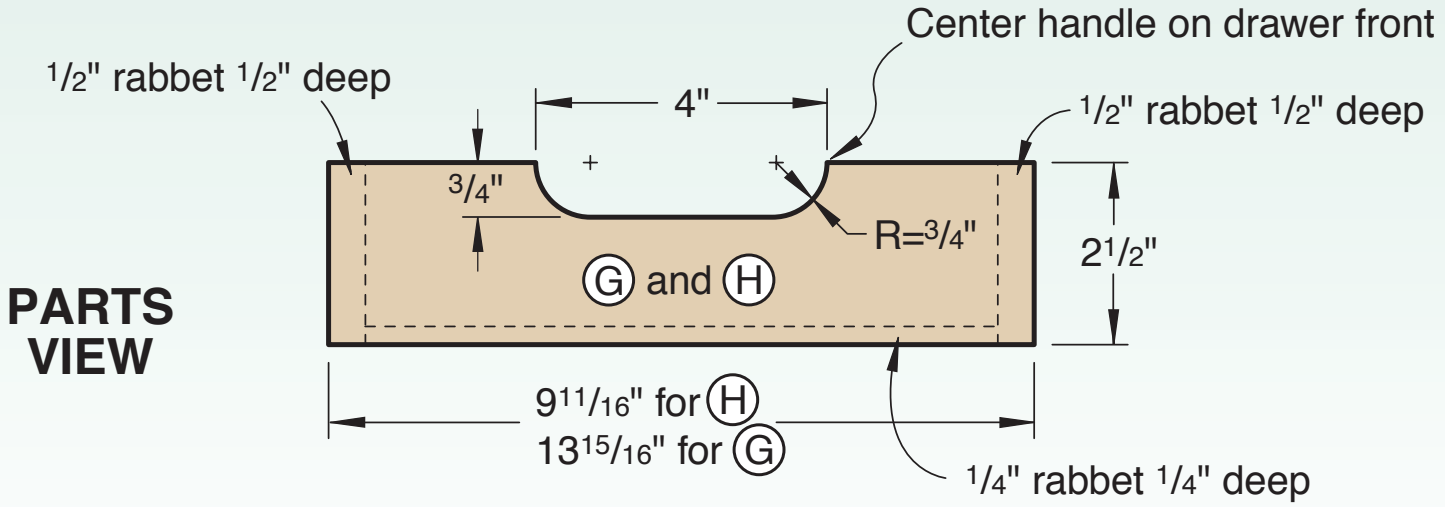

PARTS VIEW

DRAWER FRONTS

Bill of Materials

| Part | Finished Size | | | Mati. | Qty. |
|-----------------|---------------|---------|-----------|-------|------|
| | T | W | L | | |
| A top | 3/4" | 8" | 26" | PW | 1 |
| B bottom | 3/4" | 10 3/4" | 26" | PW | 1 |
| C back | 3/4" | 2 1/2" | 26" | PW | 1 |
| D end | 3/4" | 2 1/2" | 8" | PW | 2 |
| E divider | 3/4" | 2 1/2" | 7 1/4" | PW | 1 |
| F cleat | 3/4" | 3/4" | 10" | PW | 2 |
| G drawer front | 3/4" | 27/16" | 13 15/16" | PW | 1 |
| H drawer front | 3/4" | 27/16" | 9 11/16" | PW | 1 |
| I drawer side | 1/2" | 27/16" | 7" | PW | 4 |
| J drawer back | 1/2" | 27/16" | 13 7/16" | PW | 1 |
| K drawer back | 1/2" | 27/16" | 9 3/16" | PW | 1 |
| L drawer bottom | 1/4" | 6 1/2" | 13 7/16" | PW | 1 |
| M drawer bottom | 1/4" | 6 1/2" | 9 3/16" | PW | 1 |

Materials Key: PW—Baltic birch or cabinet-grade plywood.

Supplies: Mounting bolts to suit lathe, #8×1" and 1 1/4" flathead wood screws, woodworker's glue, clear polyurethane finish.